



Product Cochinita Pibil	Brand Marhel	Net Content 250 g
-----------------------------------	------------------------	-----------------------------

Last update date January, 2017.

DESCRIPTION

Shredded pork and seasoned with the traditional pibil, vacuum packed in a pouch bag and heat-treated to commercial sterility.

Presentation of 250g.

Ingredients:
pork, achiote paste (water, tomato paste, achiote, garlic, spices, iodized salt), lard, vinegar, soy fiber and iodized salt.

NUTRITIONAL INFORMATION

Nutritional Information

Portion size 100g
Servings per container 2.5

Energetic content 1.006 KJ (241 kcal)

Carbohydrates	3.4 g
Protein	19 g
Fat	16.6 g
Saturated fat	6.1 g
Other fats	-
Cholesterol	-
Sodium	350 mg
Dietary fiber	1 g
Sugars	3.4 g





Product
Cochinita Pibil

Brand
Marhel

Net Content
250 g

Last update date January, 2017.

PACKING

PRIMARY PACKAGING

Description: PET12/AL9/NY25/RCP80MIC

Specification: 1 pouch with 250g of product.

Dimensions	Measure	Unit
------------	---------	------

Ancho	135	mm
Largo	180	mm
Fuelle	35	mm
Muesca	25	mm

Composition

Composition

Layer	Material	Thickness	Unit
1	ALOX	12	µm
2	Nylon	15	µm
3	CPP	100	µm

PRIMARY PACKAGING

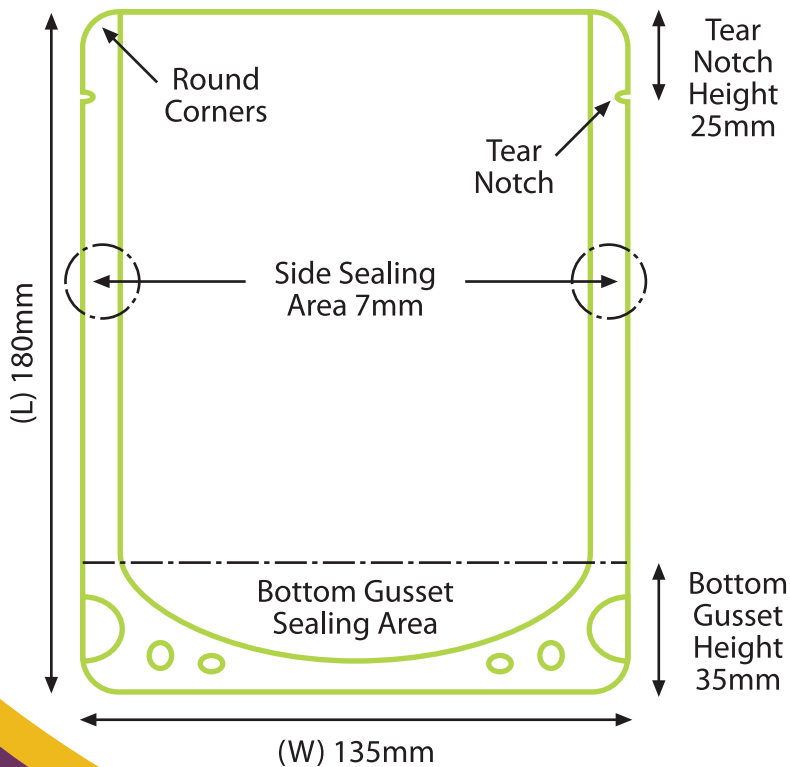

SECONDARY PACKAGING

Description:
Corrugated carton box.

Dimensions:
270 x 140 x 180 mm

Specification:
1 box of 12 pieces
(250g pouches each)



Product
Cochinita Pibil

Brand
Marhel

Net Content
250 g

Last update date January, 2017.

STORAGE

The product should be handled at room temperature, stored out of heat or sunlight, once opened keep refrigerated, do not open boxes with sharp tools.

Life of anaquel: Up to 2 years under the conditions described.

TRANSPORTATION CONDITIONS

Shipping in clean transport, free of foreign material and pests that affect the safety and integrity of the product.

REJECTION CONDITIONS

Avoid consuming the product if it has defects such as: cracks, bulging, product runoff, microbiological deviations.

Cautions: Do not consume if the container shows any perforation, cracks, bulging or any sign of deterioration or decomposition.

BARCODE

Cochinita
Pibil
Marhel
Pouch of 250g





Product
Cochinita Pibil

Brand
Marhel

Net Content
250 g

Last update date January, 2017.

STORAGE ESTIBA

Configuration	Quantity	Units
Weight per bag	0.25	kg
Bags per box	12.00	pcs
Boxes per bed	28.00	boxes
Deck levels	8.00	levels
Pallets per pallet	224.00	boxes
Box weight	3.00	kg
Pallet weight	672.00	kg
Platforms / Trailer	26.00	pallets
Trailer weight	17,472.00	kg
Parts / trailer	69,888.00	pcs
Boxes / trailer	5,824.00	boxes

Flattened

- Vitafil material
- 5 turns bottom
- 5 turns intermediate part
- 5 turns top



*Suggested packaging, may vary according to the needs of each client.



Plaza Bahia Marina No. 2212 int. 19 y 20, en Av. La Marina Mazatlán, Sinaloa, México. C.P.82112

✉ ventas@marhel.com.mx

🌐 www.marhel.com.mx

☎ ++52 (669) 688 5083